

AX00128 : PORTE VERRE IX

CRISTINA
RUBINETTERIE

ondyna

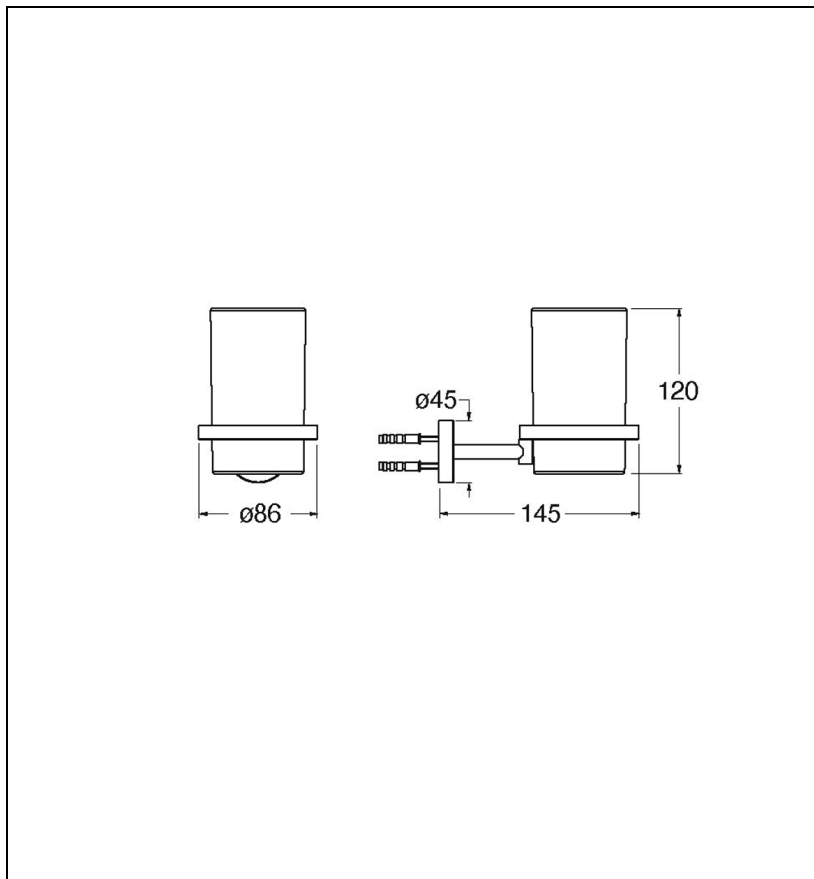

28 > inox AISI 316 L

Caractéristiques

- Rosace Ø 45 mm
- Hauteur 120 mm
- Saillie 145 mm
- Garantie 8 ans